

IMCA Northern SportMod Body Dimensions For 2014

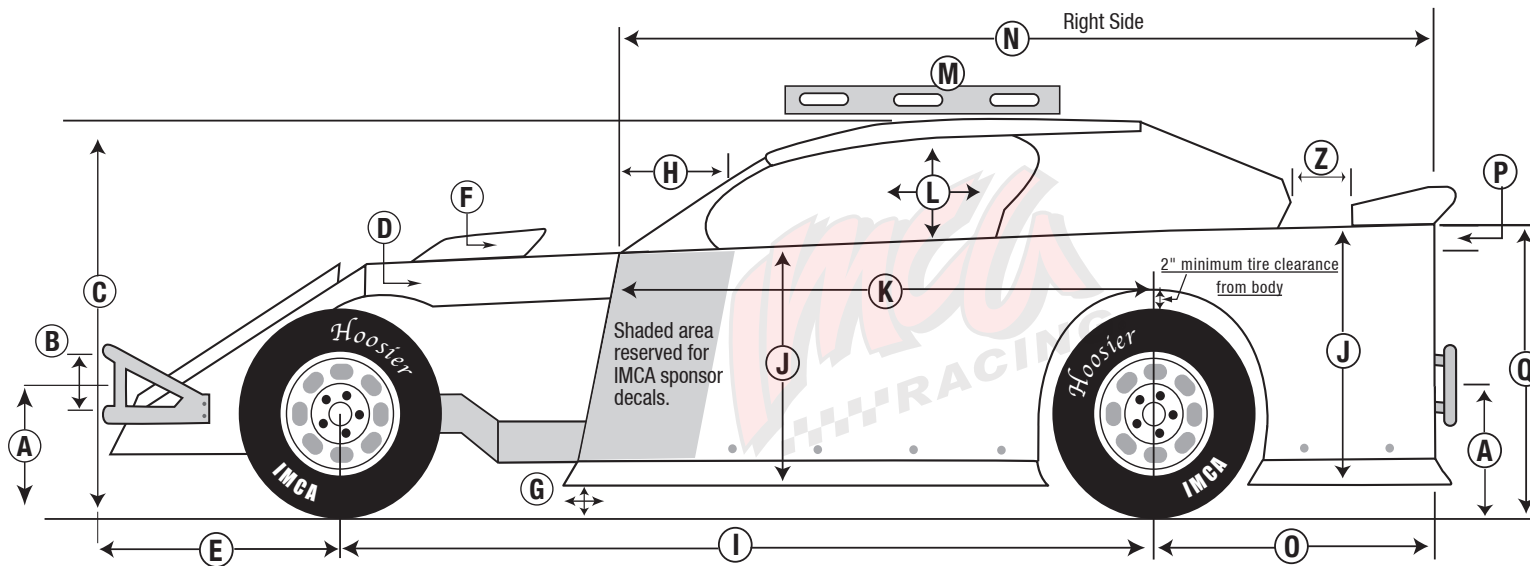

All body measurements are max. unless otherwise specified. Dimensions have zero tolerance.

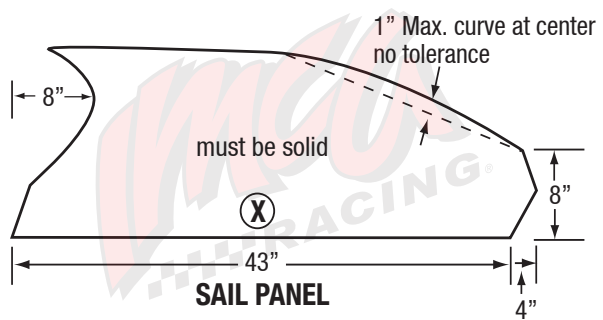
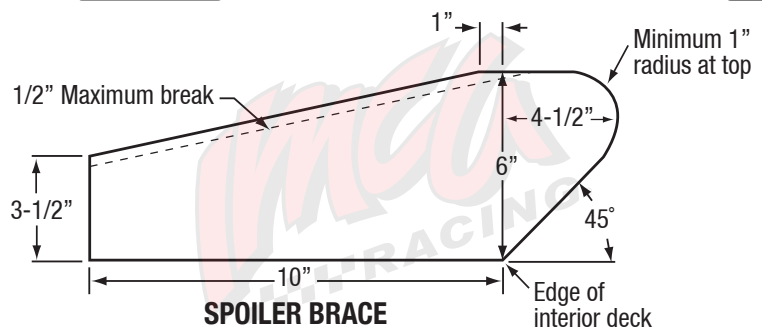
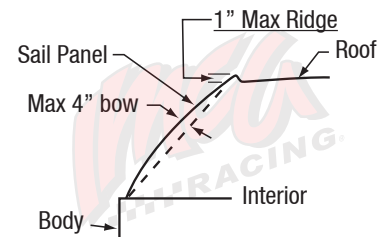
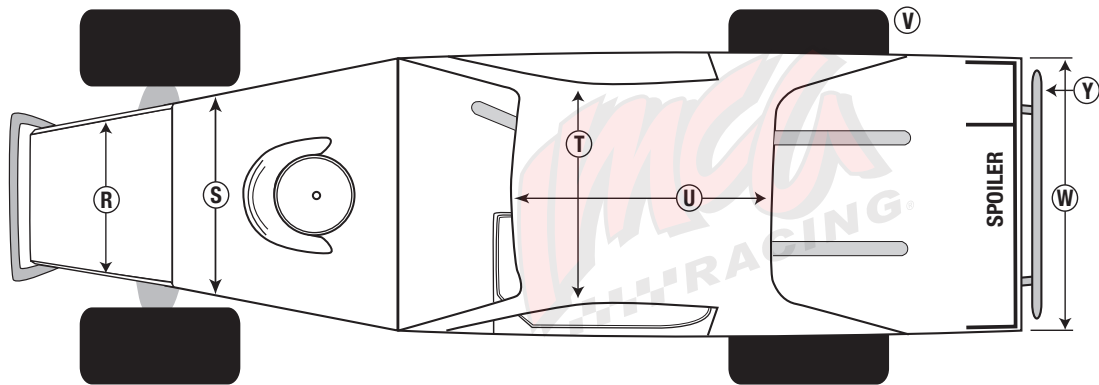

- A** 20" max. 16" min. (ground to center of bumpers, front and rear)
- B** 6.5" min. (center to center)
- C** 54" max. 42" min.
- D** Hood 6" max. drop (sides), sealed off from driver's compartment and max. 3" rake.
- E** 36" max.
- F** 6" max.
- G** 4" min. ground clearance; Door may extend max. 6" past block at bottom, both sides.
- H** 19" max., must be same on both sides.
- I** 112" max. 108" min.
- J** 31" max. 22" min.
- K** 72" max. or not past back of block, at top. Left side may extend forward to cover foot box.
- L** 18" max. 12" opening, both sides.
- M** With level, must have no more than 2" clearance at rear of roof and 5" at top front.
- N** 120" max. 106" min.
- O** 48" max. 34" min.
- P** Interior slope is 6" max. front to rear and flat across. If flat at front half of interior you have used up 50% of your 6" so from behind driver to rear you may only have 3". Top of interior must be flush with top of doors and quarters. Optional escape hatch from driver to passenger door allowed.
- Q** 38" max. 28" min.
- R** Min. 24" nose must be flat and flush with sides.
- S** 66" max. 24" min. must cover radiator.
- T** 52" max. 44" min.
- U** 56" max. 41" min.
- V** All tires must be outside body and nerfbar and visible from front, rear & top.
- W** 66" max. 53" min. same front to back
- X** 43" max. 24" min.
- Y** IMCA decal required on filler panel.
- Z** 3" minimum
- REAR FILLER PANEL:** 8" min. / 90 degree angle. Must be solid, attached to deck, extend to quarter panels, securely fastened.
- SPOILER BRACES:** Maximum 3 total. Bottom edge of spoiler brace must be flush with rear edge of interior deck.
- SAIL PANELS:** Must slope down from rear edge of roof and be within confines of these dimensions and the same on both sides. Must mount within 2" of outside edge of interior deck.