

# IMCA Modified Body Dimensions For 2016

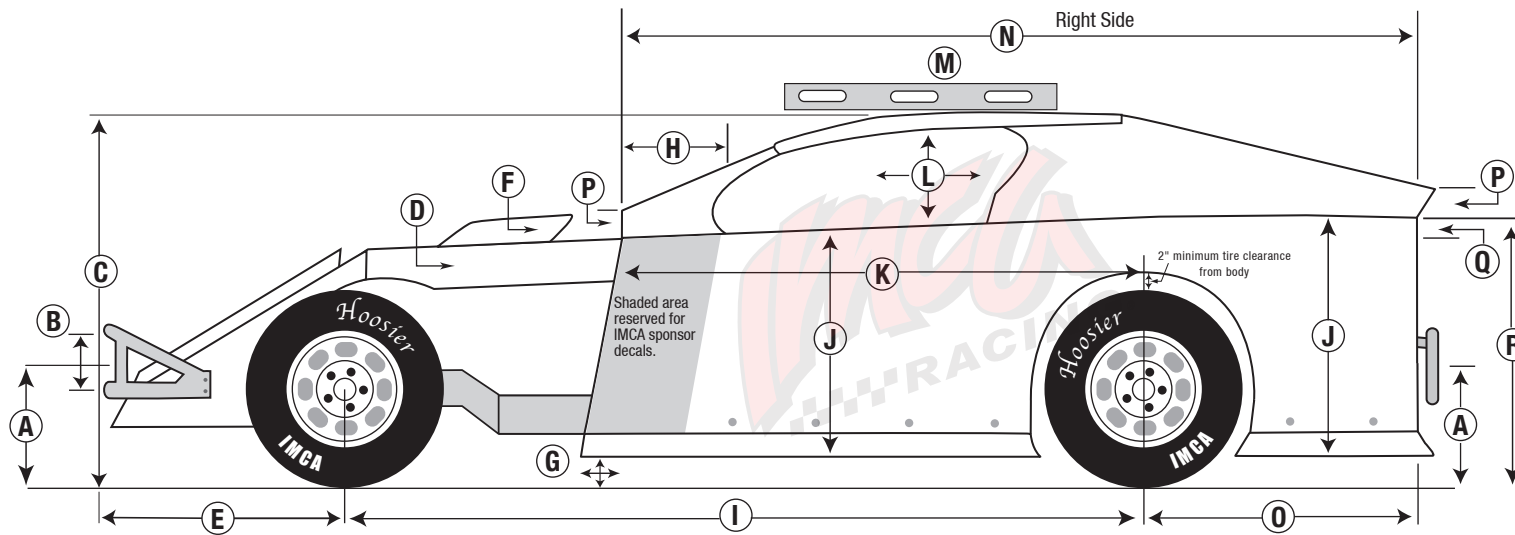

All body measurements are max. unless otherwise specified. Dimensions have zero tolerance.

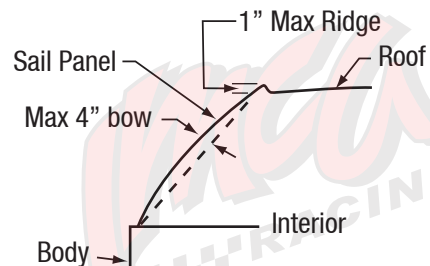
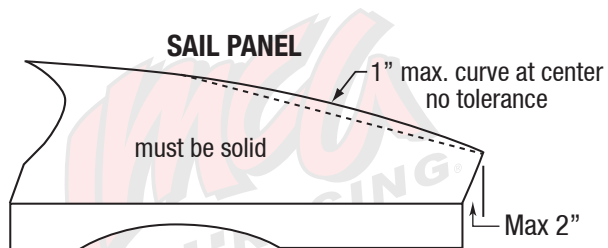
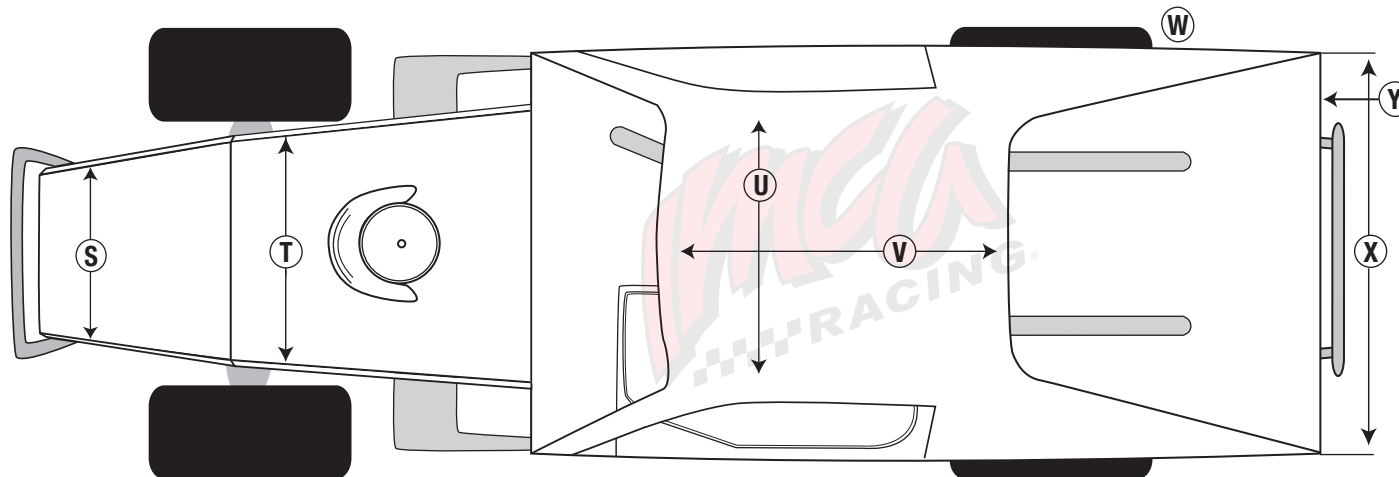

- A** 20" max. 16" min. (ground to center of bumpers, front and rear)
- B** 6.5" min. (center to center)
- C** 54" max. 42" min.
- D** Hood 6" max. drop (sides), sealed off from driver's compartment and max. 6" rake.
- E** 36" max.
- F** 6" max. scoop cannot extend past front of hood.
- G** 4" min. ground clearance; Door may extend max. 6" past block at bottom, both sides.
- H** 19" max., must be same on both sides.
- I** 112" max. 108" min.
- J** 31" max. 22" min.
- K** 72" max. or not past back of block at top. Left side may extend forward to cover foot box.
- L** 18" max. 12" min. opening, both sides.
- M** With level, must have no more than 2" clearance at rear of roof and 5" at top front.
- N** 120" max. 106" min.
- O** 48" max. 34" min.
- P** 4" max. at front and rear, gradual slope from roof to this point.
- Q** Interior slope is 6" max. front to rear and flat across. If flat at front half of interior you have used up 50% of your 6" so from behind driver to rear you may only have 3". Top of interior must be flush with top of door and quarter panels. Optional escape hatch from driver to passenger door allowed.
- R** 38" max. 28" min.
- S** Min. 24" nose must be flat and flush with sides.
- T** 66" max. 24" min., must cover radiator
- U** 52" max. 44" min.
- V** 56" max. 41" min.
- W** Tires max 1" inside body both sides.
- X** 66" max. 53" min. same front to back.
- Y** IMCA decal required on filler panel.
- REAR FILLER PANEL:** 8" min. / 90 degree angle. Must be solid, attached to deck, extend to quarter panels, securely fastened.
- SAIL PANELS:** Must slope down from rear edge of roof and extend from roof to rear of car and be the same on both sides. May extend 2" maximum past rear edge of interior deck. Must mount within 2" of outside edge of interior deck.