

# 1978-1987 Chevrolet Monte Carlo Frame

20200227

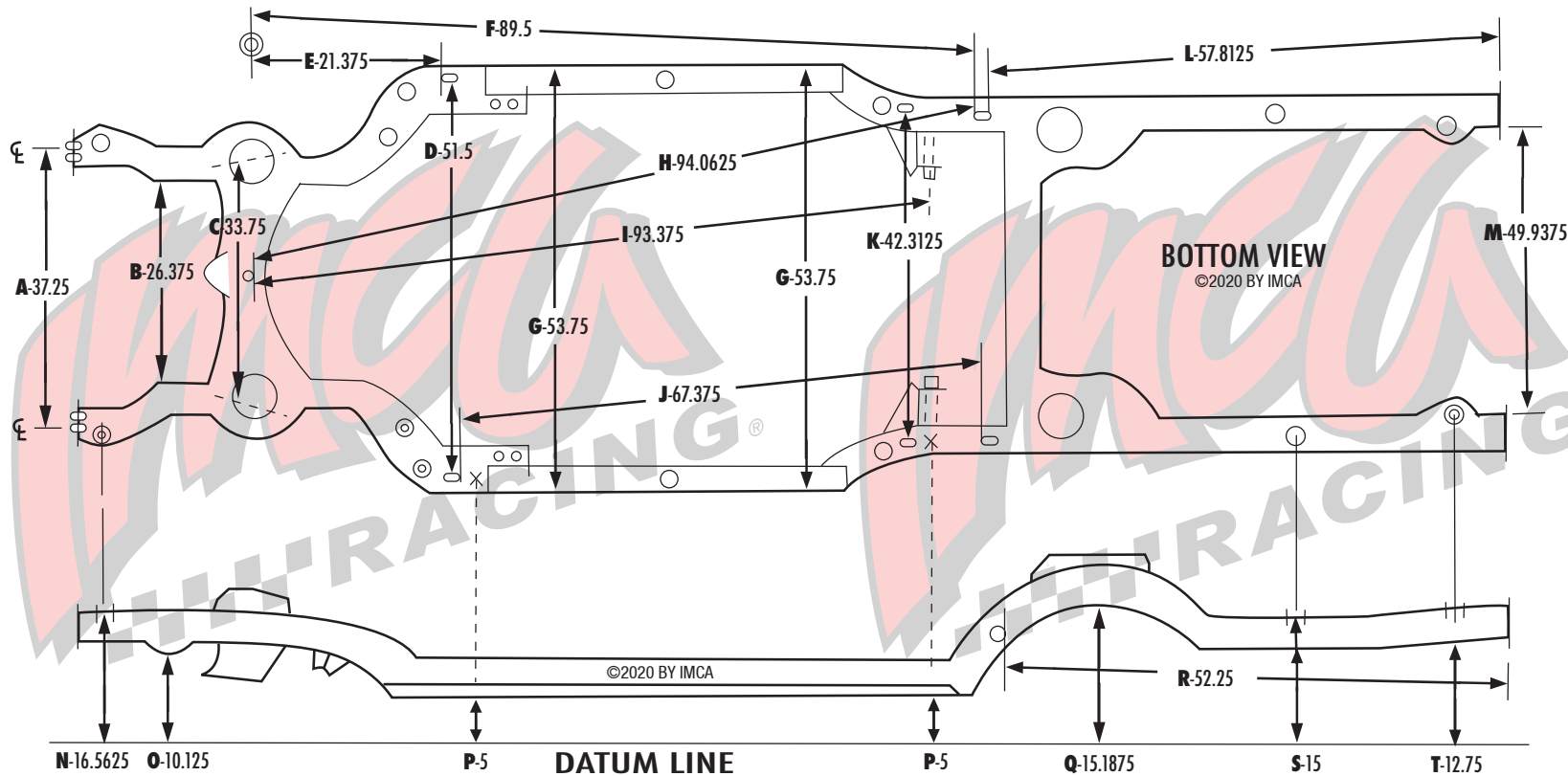

- Dimensions are to either the top or bottom surface of the frame rail as indicated.

- All dimensions must be within 0.250-inch tolerance. Exceptions are variances officials verify as crash damage.

- A.** 37.25 - inches from center to center of bumper cylinder lower flange mounting holes.
- B.** 26.375 - inches between side rails at lower steering gear bolt area, to idler arm mounting area.
- C.** 33.750 - inches between upper control arm mounting brackets at front shim area.
- D.** 51.5 - inches from inside edge of slotted hole, to inside edge of slotted hole. Hobby Stock front firewall can be located no further back than the rear edge of this hole
- E.** 21.375 - inches from center of lower ball joint grease fitting to front edge of slotted hole.
- F.** 89.5 - inches from center of lower ball joint grease fitting, to front edge of rear slotted hole.
- G.** 53.750 - inches from outside edge of frame rail to outside edge of frame rail.

- H.** 94.0625 - inches from rear edge of crossmember hole, to front edge of rear slotted hole.
- I.** 93.375 - inches from rear edge of front crossmember hole, to center of rear torque arm mounting pin.
- J.** 67.375 - inches from rear edge of slotted hole, to front edge of rear slotted hole.
- K.** 42.3125 - inches from inside edge of slotted hole, to inside edge of slotted hole.
- L.** 57.8125 - inches from rear edge of slotted hole, to lower outer flange edge of side rail.
- M.** 49.9375 - inches between lower side surfaces of rear side rails.
- N.** 16.5625 - inches from top of side rail alongside radiator support mount, to datum line.
- O.** 10.125 - inches from lowermost surface of side rail at sway bar mounting area, to datum line.

- P.** Locations for measuring ride height. Dimensions N, O, Q, S and T should be measured at 5 inch ride height. Front, 5 inches below bottom surface of side rail just rear of slotted hole; Rear, 5 inches below bottom surface of side rail alongside front slotted hole.
- Q.** 15.1875
- R.** 52.250 - inches from rear edge of flanged tie down hole to lower flange edge of side rail.
- S.** 15 - inches from top surface of side rail.
- T.** 12.750 - inches from bottom surface of side rail.